

**Emergency Lighting Fixture : Item Code - PEL 210 TBL/FP
Mounting : Wall / Portable, (Type – Non Maintained)**

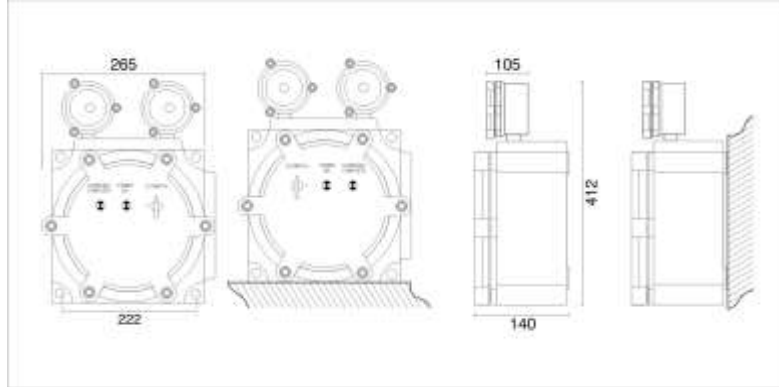

Consist of two units of LED Lamps, automatically switches – **ON**, on mains power failure & provides illumination on battery source for specified duration, after which the battery gets automatically cut-off, to facilitate quick recharge on the resumption of mains supply. Once the battery is fully charged, it automatically slides into trickle charge to constantly retain the charge and be ready for immediate use.

Dimensions (in mm)



TECHNICAL SPECIFICATIONS		MONOGRAM OF PROLITE
Product Make	PROLITE	
Applicable Standard	IS 9583 of 1981	
Housing	Cast aluminum, CMRI certified FLAME PROOF housing with heat resistant clear BOROSIL GLASS .	
Type of Protection	Flame Proof	
Type of mains Cord	3 Pin 2 yard	
Type of Design	Non-Maintained	
Ingress Protection	IP-65	
Paint & Colour	Epoxy paint, Shade 631 of IS: 5.	
Rating Lamp	2 x 10W	
Nominal Working Voltage	230V, 50Hz/A.C. (+ 10%)	
Battery Backup	180 Minutes back-up.	
<u>Battery</u>	SLA (Sealed Lead Acid Battery)	
a. Type	12V	
b. Voltage		
<u>Charging Device</u>	Constant Voltage Charger	
a. Type	10-12 Hrs.	
b. Time Required for Charging		
<u>Lamp</u>	Tungsten Halogen Lamp	
a. Type	2 x 10W	
b. Rating		
Red Led	Charging Indication	
Weight (Kg)	8 Kg. Approx.	
Mounting	On wall thru bracket provided.	
Application	Industrial purpose, in chemical & hazardous industries, where ignition of inflammable material is very casual.	

FOR,

PROLITE AUTOGLO LIMITED

DATE: