

**Emergency Lighting Fixture : Item Code - PEL 240 NM/SL
(Type - Non-Maintained)**

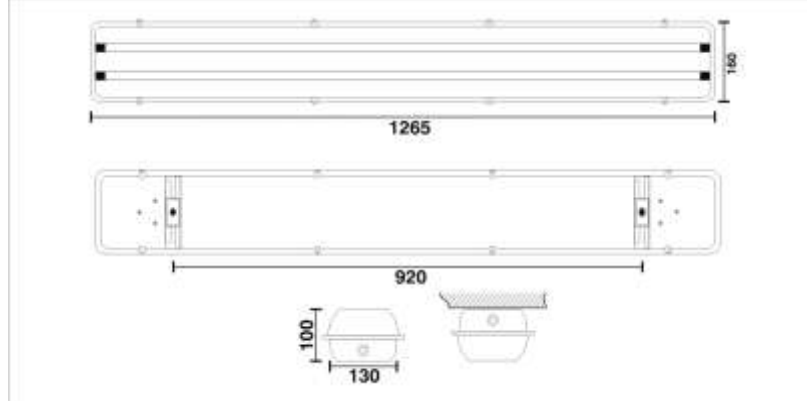

Consist of twin FT - Ls which provides illumination on normal mains power supply and the same lamp/s continues to provide illumination during mains failure on self contained battery source. **ON** resumption of mains supply, the lamp/s switches back to the mains automatically & simultaneously starts recharging the battery to the required level. **Non-Maintained models provide uninterrupted illumination.**

Dimensions (in mm)



TECHNICAL SPECIFICATIONS

MONOGRAM OF PROLITE

Confirms	IS : 9583 - 1981.
Ingress Protection	IP - 65.
Housing	Molded ABS, grey in colour.
Diffuser	Molded ABS, clear reeded finish.
Reflector	Made up of C. R. C. A. Sheet steel.
Paint & Colour	Epoxy polyester powder coating, White in colour.
Lamp Holder	Base : G13, Rotor holder suitable for (T - 12) FT - L, White Polycarbonate/ABS with electrical grade brass contact.
Input (V)	~ 230 Volts, 50 Hz.
Lamp	2 x FT - L (T - 12) 36/40 Watts.
Lamp make	Osram, Philips, Surya
Mains Connector	6 A, 250 Volts, Milky white Polycarbonate with electrical grade brass contacts.
Battery type	S. L. A., rechargeable.
Duration	60 Minutes back up; \pm 10%.
Charging Type	Constant voltage charger.
Recharging Cycle	10 to 12 hours recharging period.
Mounting	Surface mounting type.
Weight (Kg)	5 kg. Approx
Application	For outdoors of domestic & commercial premises, corridors of hotels, Battery & pump rooms, staircases, underground parking.
Tolerance on overall dimensions is \pm 5 m. m. unless otherwise specified.	
Please Note: Other Input Voltage Is Also Available - Price On Request (POR).	
Due to continuous development, specifications may change without prior notice.	

FOR

PROLITE AUTOGLO LIMITED

DATE :