

**Emergency Lighting Fixture : Item Code - PEL 220 TBL
Mounting : Wall/Portable, (Type – Non Maintained)**

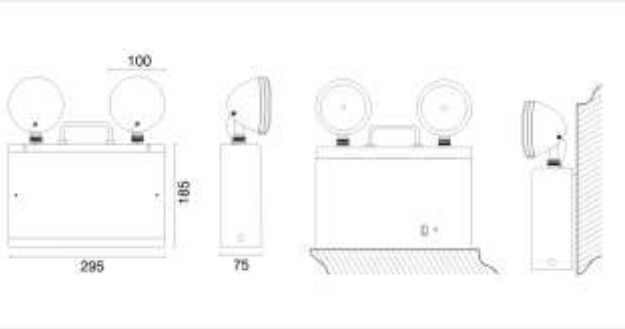

Consist of two 20 Watts Tungsten Halogen lamps, automatically switches – **ON**, on mains power failure & provides illumination on battery source for specified duration, after which the battery gets automatically cut-off, to facilitate quick recharge on the resumption of mains supply. Once the battery is fully charged, it automatically slides into trickle charge to constantly retain the charge and be ready for immediate use.

Dimensions (in mm)



TECHNICAL SPECIFICATIONS

MONOGRAM OF PROLITE

Confirms	IS : 9583 – 1981.
Ingress Protection	IP – 20.
Housing	M. S., C. R. C. A. fabricated, 22 S. W. G.
Diffuser	Hardened Glass.
Reflector	Well countered, Electrochemically brightened, made up of C. R. C. A. Sheet steel, duly housed in a sheet steel enclosure having panning & tilting arrangements.
Paint & Colour	Epoxy polyester powder coating, White in colour.
Lamp Holder	Body LCP, Base : G6.35,
Input (V)	~ 230 Volts, 50 Hz.
Lamp	2 x 20 Watts Tungsten Halogen Lamps.
Mains Connector	5 A, 250 Volts, Milky white Polycarbonate with electrical grade brass contacts.
Battery type	SLA Rechargeable.
Duration	90 Minutes back up; \pm 10%.
Charging Type	Constant voltage charger.
Recharging Cycle	10 to 12 hours recharging period.
Mounting	Wall/Portable type.
Weight (Kg)	5 Kg. Approx
Indications	Red LED "ON" indicates charging.
Application	For outdoors of domestic & commercial premises, corridors of hotels, Battery & pump rooms, staircases, underground parking.
Tolerance on overall dimensions is \pm 5 m. m. unless otherwise specified.	
Please Note: Other Input Voltage Is Also Available – Price On Request (POR).	
Due to continuous development, specifications may change without prior notice.	

FOR

PROLITE AUTOGLO LIMITED

DATE :