

**Emergency Lighting Fixture : Item Code - PEL 150 HSL
Mounting : Portable, (Type – Non Maintained)**

Portable



Consist of one Tungsten Halogen lamp, automatically switches – **ON**, on mains power failure & provides illumination on battery source for specified duration, after which the battery gets automatically cut-off, to facilitate quick recharge on the resumption of mains supply. Once the battery is fully charged, it automatically slides into trickle charge to constantly retain the charge and be ready for immediate use.

G.A. Drawing :

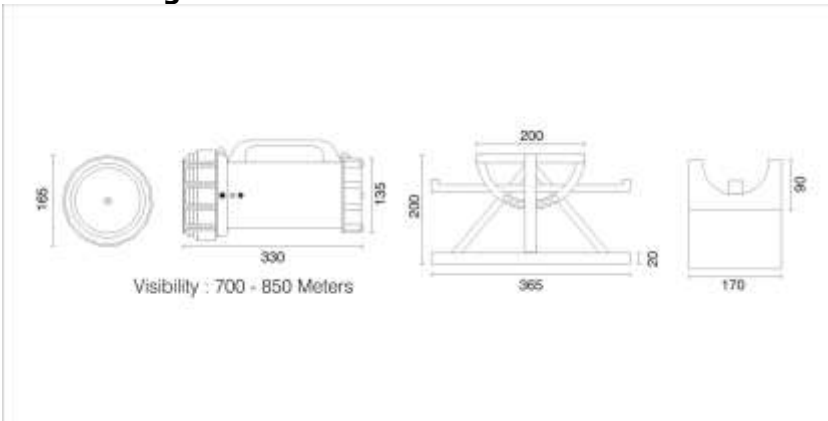

TECHNICAL SPECIFICATIONS

Confirms	IS : 9583 – 1981.
Ingress Protection	IP – 43.
Housing	Impact resistant molded ABS/Polycarbonate in single tone.
Diffuser	Hardened Glass.
Reflector	Well countered, Electrochemically brightened, made up of C. R. C. A. Sheet steel, duly housed in ABS/Polycarbonate body housing.
Paint & Colour	Pigmented molten ABS.
Lamp Holder	H3 Type
Input (V)	~ 230 Volts, 50 Hz.
Lamp	1 x 50 Watts Tungsten Halogen Lamp.
Mains Connector	5 A, 250 Volts, Milky white Polycarbonate with electrical grade brass contacts.
Battery type	SLA Rechargeable.
Duration	90 Minutes back up; \pm 10%.
Charging Type	Constant voltage charger.
Recharging Cycle	10 to 12 hours recharging period.
Mounting	Portable type.
Weight (Kg)	5 Kg. Approx
Indications	Red LED "ON" indicates charging.
Application	Very useful for security guards because of narrow, sharp & long ranged light beam, outdoors of domestic & commercial premises, corridors of hotels, Battery & pump rooms, underground parking.
Additional Feature	Equipped with PUSH Test switch.
Optional Attachment	A robust stand made of aluminum to have a table top use.

Tolerance on overall dimensions is \pm 5 m. m. unless otherwise specified.

Please Note: Other Input Voltage Is Also Available – Price On Request (**POR**).

Due to continuous development, specifications may change without prior notice.