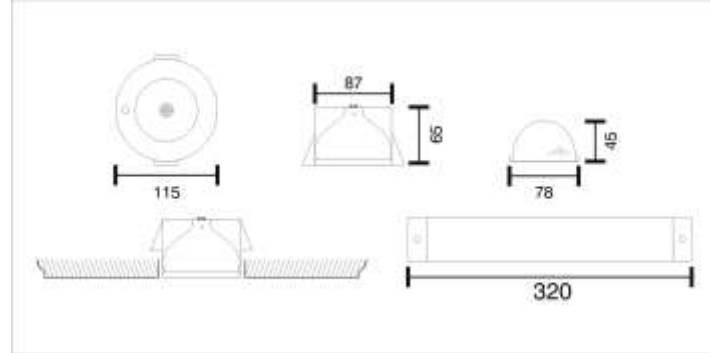

Emergency Lighting Fixture : Item Code - PEL 110 RSL (H)**Mounting : Recess, (Type – Non Maintained)**

Recessed decorative halogen down lighters, with all other features of Non – maintained recessed spot light.

DIMENSIONS IN M. M.**TECHNICAL SPECIFICATIONS**

Confirms	IS : 9583 – 1981.
Ingress Protection	IP – 20.
Lamp Housing	Lamp housing made up of cast aluminum.
Mounting	Recessed mounting type.
Control Gear Housing	Made up of C. R. C. A. Sheet steel – 22 S. W. G.
Paint & Colour	Epoxy polyester powder coating, White in colour.
Visor	Clear/Patterned hardened glass visor.
Reflector	Electrochemically brightened aluminum reflector.
Lamp Holder	Body LCP, Base : G6.35
Input (V)	~ 230 Volts, 50 Hz.
Lamp	1 x Tungsten Halogen 6 Volts, 10 Watts.
Mains Connector	5 A, 250 Volts, Milky white Polycarbonate with electrical grade brass contacts.
Battery type	Ni-Mh/Ni-Cd; rechargeable.
Duration	2 Hours back up; \pm 10%.
Charging Type	Constant current charger.
Recharging Cycle	16 to 24 hours recharging period.
Weight (Kg)	2 Kg. Approx
Indications	Red LED "ON" indicates charging.
Application	Domestic & commercial purpose, corridors of hotels, Battery rooms, staircases, underground parking.
Tolerance on overall dimensions is \pm 5 m. m. unless otherwise specified.	
Please Note: Other Input Voltage Is Also Available – Price On Request (POR) .	
Due to continuous development, specifications may change without prior notice.	

FOR

PROLITE AUTOGLO LIMITED

DATE :