

Emergency Lighting Fixture : Item Code - PEL 10 HSL
Mounting : Portable, (Type – Non Maintained)

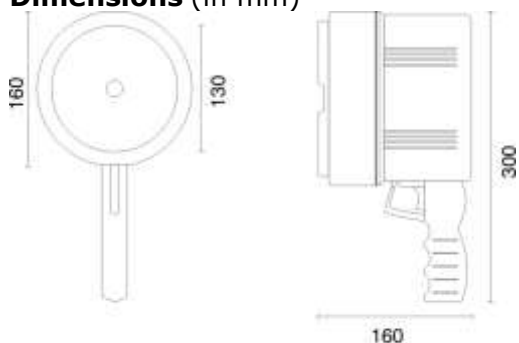

Consist of one Tungsten Halogen lamp, automatically switches – **ON**, on mains power failure & provides illumination on battery source for specified duration, after which the battery gets automatically cut-off, to facilitate quick recharge on the resumption of mains supply. Once the battery is fully charged, it automatically slides into trickle charge to constantly retain the charge and be ready for immediate use.

Dimensions (in mm)



Visibility : 300 - 500 Meters

TECHNICAL SPECIFICATIONS

Confirms	IS : 9583 – 1981.
Ingress Protection	IP – 20.
Housing	Impact resistant molded ABS/Polycarbonate in single tone.
Diffuser	Hardened Glass.
Reflector	Well countered, Electrochemically brightened, made up of C. R. C. A. Sheet steel, duly housed in ABS/Polycarbonate body housing.
Paint & Colour	Pigmented molten ABS/Polycarbonate.
Lamp Holder	H 3 Type
Input (V)	~ 230 Volts, 50 Hz.
Lamp	Tungsten Halogen Lamp.
Battery type	SLA Rechargeable.
Duration	30 mins battery back up; \pm 10%.
Charging Type	Constant voltage charger.
Recharging Cycle	10 to 12 hours recharging period.
Mounting	Portable type.
Weight (Kg)	2 Kgs
Indications	Red LED "ON" indicates charging.
Application	Very useful for security guards because of narrow, sharp & long ranged light beam, outdoors of domestic & commercial premises, corridors of hotels, Battery & pump rooms, underground parking.

Tolerance on overall dimensions is \pm 5 m. m. unless otherwise specified.

Please Note: Other Input Voltage Is Also Available – Price On Request (**POR**).

Due to continuous development, specifications may change without prior notice.

FOR

PROLITE AUTOGLO LIMITED