

**Emergency Lighting Fixture : Item Code - PEL 225 TBL/FP  
Mounting : Wall / Portable, (Type – Non Maintained)**

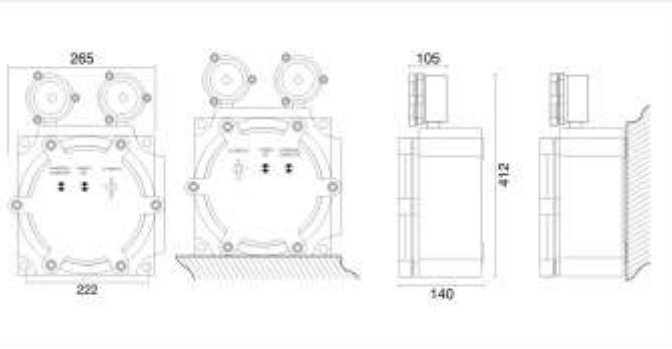

Consist of two units of LED Lamps, automatically switches – **ON**, on mains power failure & provides illumination on battery source for specified duration, after which the battery gets automatically cut-off, to facilitate quick recharge on the resumption of mains supply. Once the battery is fully charged, it automatically slides into trickle charge to constantly retain the charge and be ready for immediate use.

**Dimensions (in mm)**



**TECHNICAL SPECIFICATIONS**

**MONOGRAM OF PROLITE**

Product Make	PROLITE
Applicable Standard	IS 9583 of 1981
Housing	Cast aluminum, <b>CMRI</b> certified <b>FLAME PROOF</b> housing with heat resistant clear <b>BOROSIL GLASS</b> .
Type of Protection	Flame Proof
Type of mains Cord	3 Pin 2 yard
Type of Design	Non-Maintained
Ingress Protection	IP-65
Paint & Colour	Epoxy paint, Shade 631 of IS: 5.
Rating	2 x 25W
Nominal Working Voltage	230V, 50Hz/A.C.
Battery Backup	90 Minutes back-up.
<u>Battery</u> a. Type b. Voltage	SLA (Sealed Lead Acid Battery) 12V
<u>Charging Device</u> a. Type b. Time Required for Charging	Constant Voltage Charger 10-12 Hrs.
<u>Lamp</u> a. Type b. Rating	Tungsten Halogen Lamp 2 x 25W
Red Led	Charging Indication
<b>Weight (Kg)</b>	8 Kg. Approx.
Mounting	On wall thru bracket provided.
Application	Industrial purpose, in chemical & hazardous industries, where ignition of inflammable material is very casual.

**FOR,  
M/S. PROLITE AUTOGLO LIMITED  
DATE:**