

**Emergency Lighting Fixture : Item Code - PEL 111 M/FP
Mounting : Wall, (Type - Maintained)**

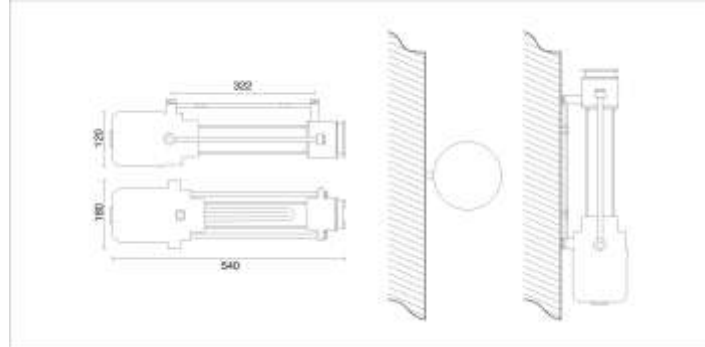

An industrial range of **FLAME PROOF** fitting which, consist of single or more CF - Ls which provides illumination on normal mains power supply and the same lamp/s continues to provide illumination during mains failure on self contained battery source. **ON** resumption of mains supply, the lamp/s switches back to the mains automatically & simultaneously starts recharging the battery to the required level. **Maintained models provide uninterrupted illumination.**

Dimensions (in mm)



TECHNICAL SPECIFICATIONS

MONOGRAM OF PROLITE

Confirms	IS : 9583 - 1981.
Housing	Cast aluminum, CMRI certified FLAME PROOF housing.
Ingress Protection	IP - 65.
Paint & Colour	Epoxy paint, Shade 631 of IS : 5.
Diffuser cum Message panel	A CAD Designed, vinyl pasted on heat resistant, clear BOROSIL GLASS diffuser.
Lamp Holder	4 pins, straight, Base : 2G7 White polycarbonate/ABS with electrical grade brass contacts.
Input (V)	~ 230 Volts, 50 Hz.
Lamp	1 x CF - L (PL - S) 11 Watts : 4 Pins Straight, high lumens out put.
Lamp make	Osram, Philips, Surya
Mains Connector	5 A, 250 Volts, Milky white Polycarbonate with electrical grade brass contacts.
Battery type	Ni-Mh/Ni-Cd; rechargeable.
Duration	120 minutes back up; \pm 10%.
Charging Type	Constant current charger.
Recharging Cycle	16 to 24 hours recharging period.
Mounting	On wall thru bracket provided.
Weight (Kg)	5 Kg. Approx
Application	Industrial purpose, in chemical & hazardous industries, where ignition of inflammable material is very casual.
Tolerance on overall dimensions is \pm 5 m. m. unless otherwise specified.	
Please Note: Other Input Voltage Is Also Available - Price On Request (POR).	
Due to continuous development, specifications may change without prior notice.	

FOR

PROLITE AUTOGLO LIMITED

DATE :